

(11)

李 義 平
前

CONTENTS

1.	
2.	
3.	
4.	가
5.	
6.	
7.	
8.	
9.	
10.	
11.	

5 .

가

가

가

가가

가

1.

(1) , 가

가

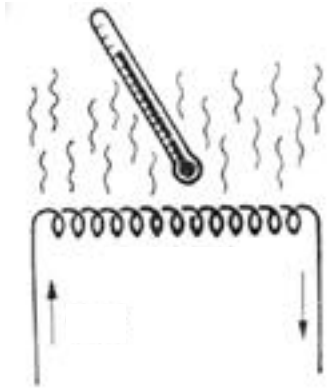

< 5-1 >

가 5-1> 가
가

가 가 가
가 가 가
가 가
가 가

가
가 가
가 가
가 가
가 가

가 .
(2)
가 가

2

가 .
가

.가 : , , , ,
. : , , ,
. : , , ,
. : 가 , , ,
. : , , ,

(3) 가
가 가
가

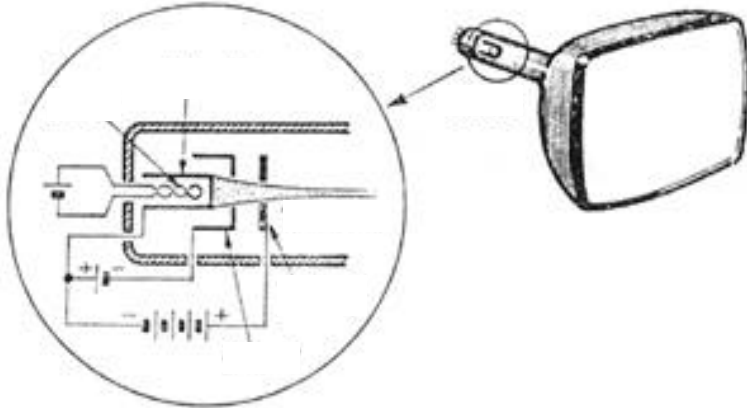

< 5-2 >

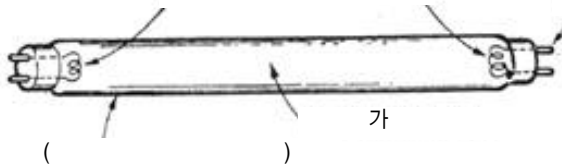

< 5-3 >

가 가 가 가 가 가 가 가 가

< 5-4 >

가 가 3,000

< 5-2 >

5-3>

(4)

가

(

< 5-1>

		[%]											
-	1	75	79	18	20	1.5		2.5	1,100	108	900		
-	2	57		15	18	21	24	3.0	900	112	,		
-	1			23	26	66	71	3.5	5.5	1.0	1,200	140	,
-	2			17	21	73	79	2	4	1.0	1,100	122	,

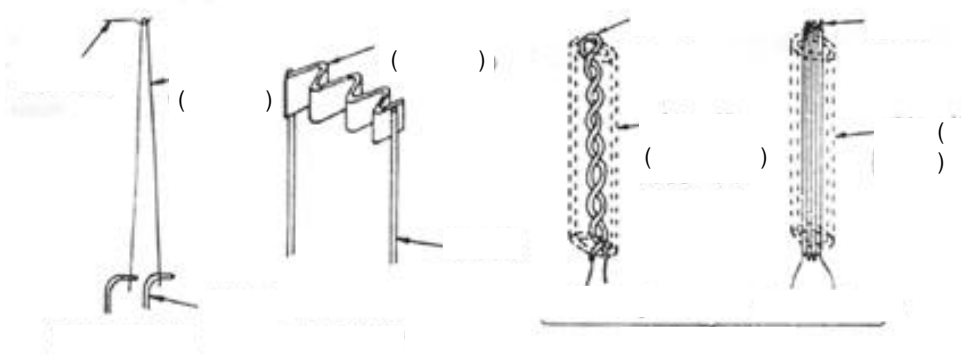

< 5-6>



< 5-7>

(2)

() 1,700

0.1

가 200 . cm

가

. 1,600

가

가

가 < 5-6>

< 5-

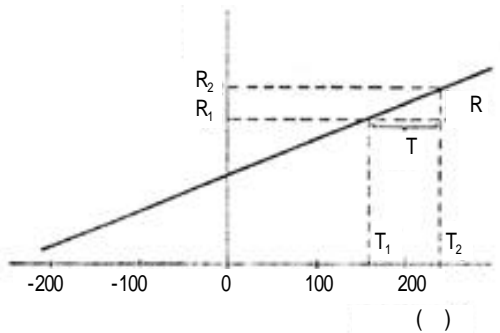

< 5-8 >

7> 가 10 20mm

(3)

가
가 (整然)

가

가

가 가

가

가

(4)

가

< 5-8 >

$$R = \frac{R_2 - R_1}{T_2 - T_1} (T - T_1) + R_1$$

$$= \frac{R}{T} \times \frac{1}{R_1} = \frac{R_2}{T_2} - \frac{R_1}{T_2} \times \frac{1}{R_1}$$

0 100

가

< 5-2 >

가

가

$$R_2 = R_1 \times (1 + \alpha \times T)$$

$T_1 []$

$R_1 []$

$T_2 []$

$R_2 []$

가 가 T

$$T = T_2 - T_1$$

< 5-9 >

가

가

0.5%

가

가

가

가

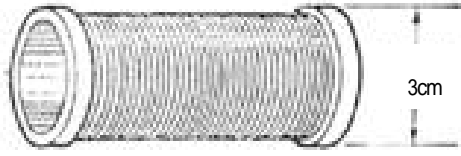

< 5-10>

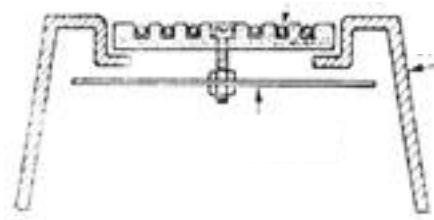

< 5-12>

가

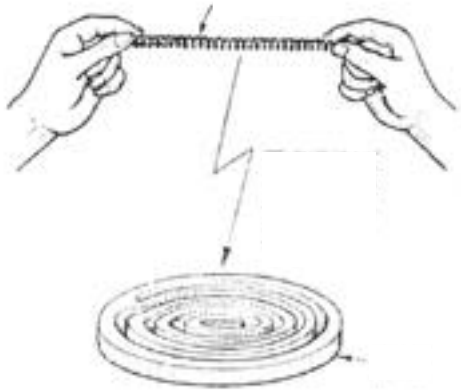

< 5-11>

()
5-11>

<

2 3mm

< 5-12>

< 5-10>

< 5-13>

()

가 가 가

가

가

()
가

5mm 가

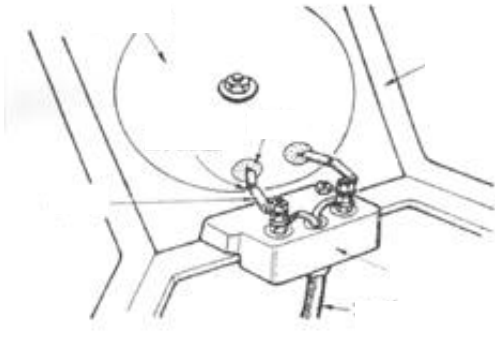

< 5-13>

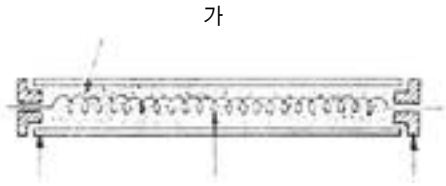

가

< 5-15>

< 5-14>

< 5-15>

() 가

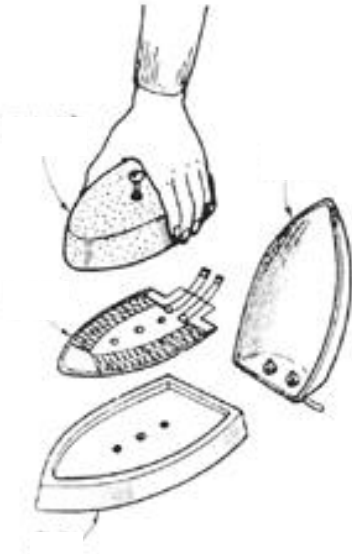

< 5-14>

가 가

< 5-16>

가

()

()

< 5-17>

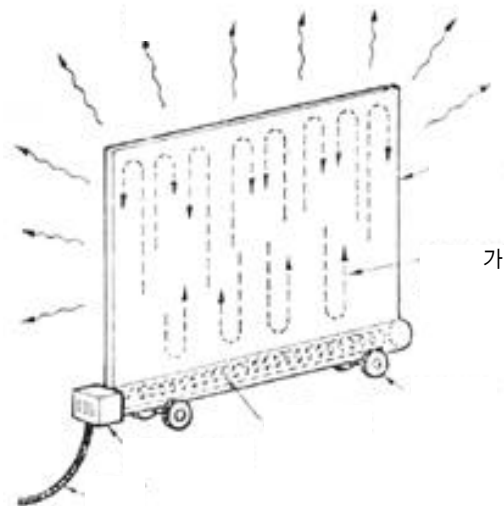

< 5-16 >

가

3.
(1)

가

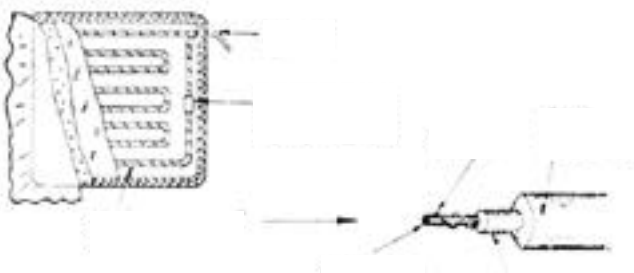

< 5-17 >

가

5-18 >

<

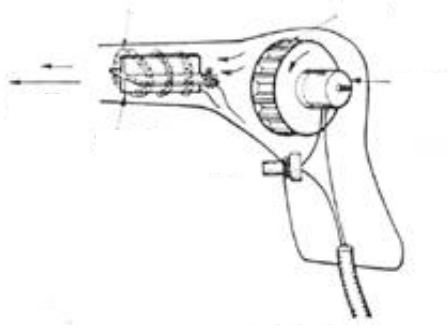

< 5-18 >

가
가

가

가

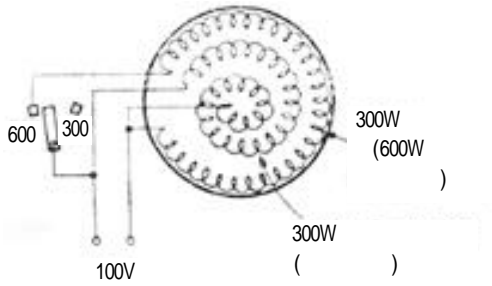

< 5-19> 300W 2 300W
600W

5-19> 600W 600W
1 300W 2
600W 가 300W
20> 가 4 5-
가
300W
2 2 , 1 , 2
, , 3

(2)

가

가

2

< 5-21>

1

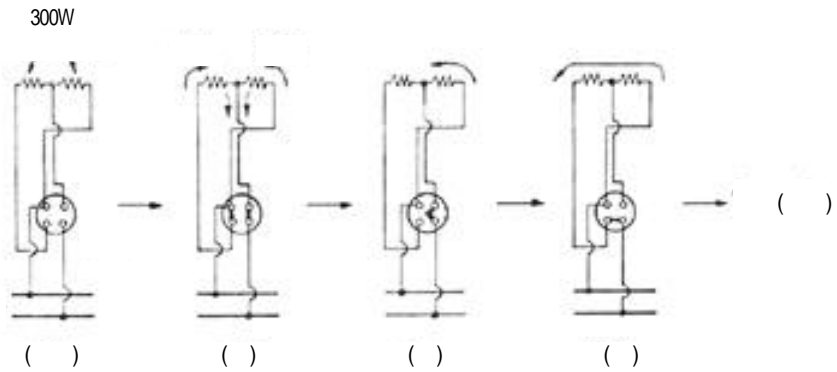

< 5-20> , , 3

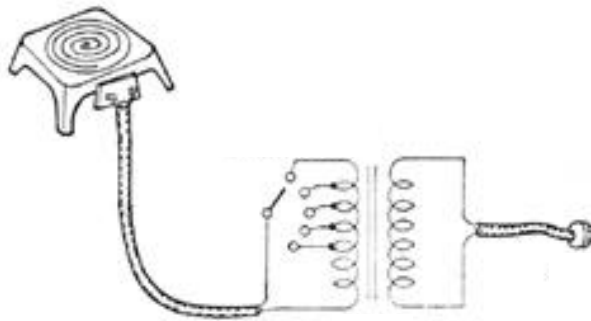

< 5-21>

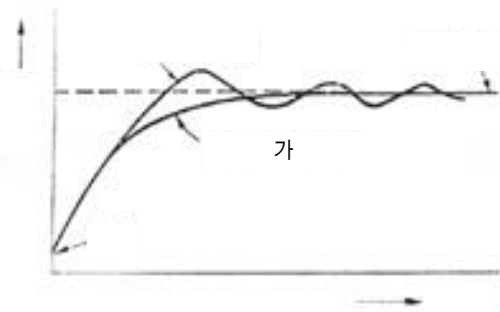

< 5-22>

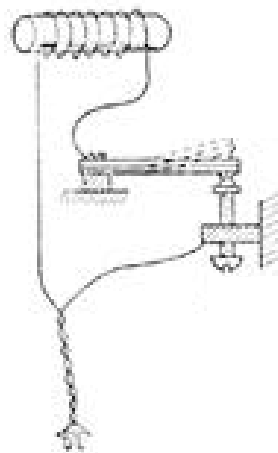

< 5-24>

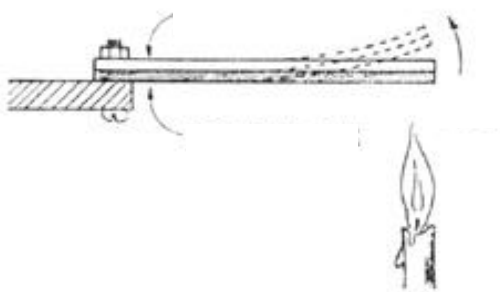

< 5-23>

가

가

가

가

< 5-22>. 가

가

가

가

가

(4)

가

가

< 5-

(3)

23>

가

가

가

가

가

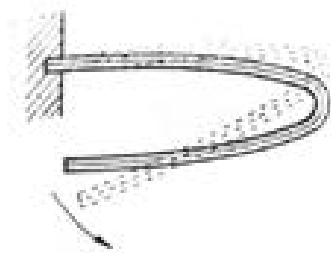

(a)

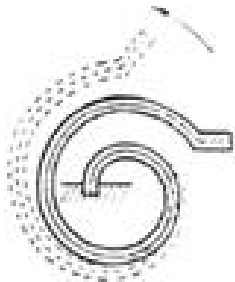

(b)

< 5-25 >

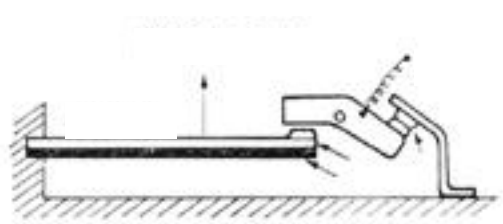
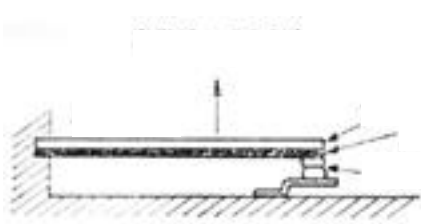

< 5-26 >

“ ” < 5-24 >

가
가

< 5-27 >

가

가
가 가

가 가

< 5-25 >

5-26 >

가

(5)

가

가

가

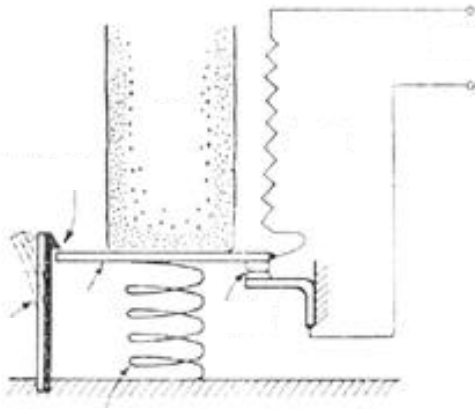

< 5-28>

가

(6)

< 5-27>

770 , 360
150

< 5-29>

가

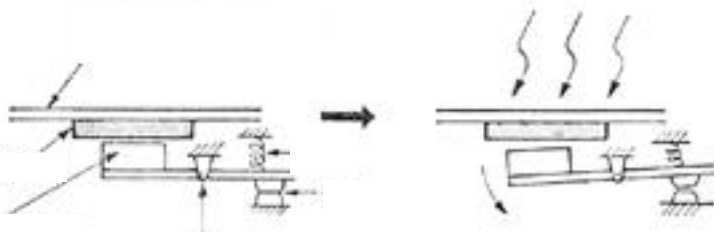

< 5-28>

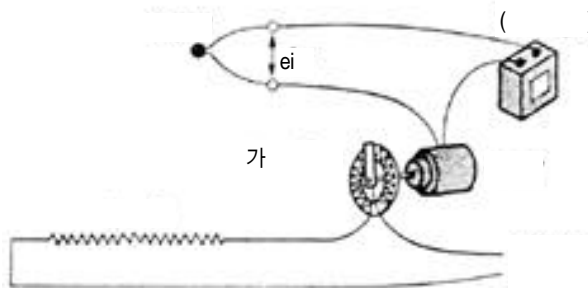

< 5-29>

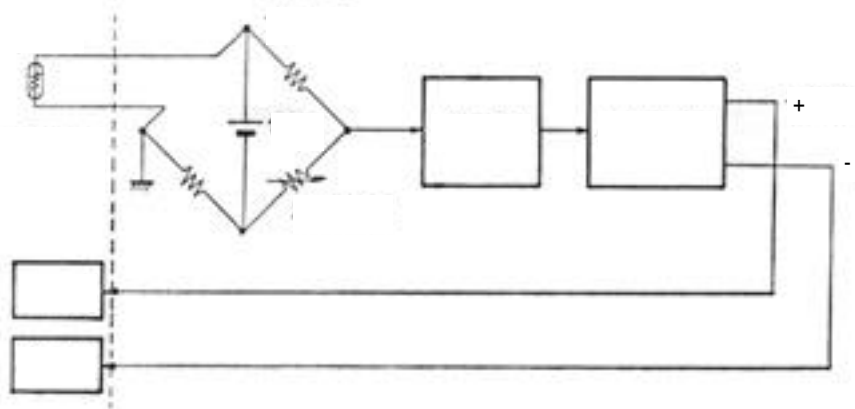

< 5-30 >

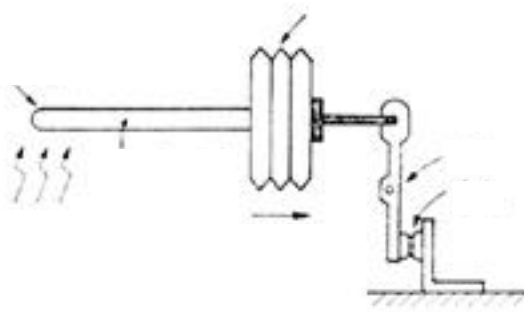

< 5-31 >

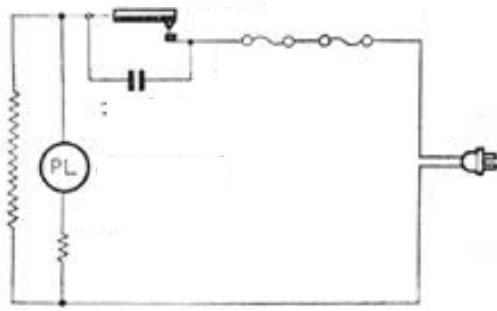

< 5-32 >

가 가
가 0 가
가
가
(IC)

< 5-30 >

IC
가
(7)

< 5-3>

[]		
110		
120		
130		
170		

< 5-31>

가 가 가 가
가 가
< 5-3> 가
가

< 5-32>

가 가 가
가 가
90 100
가 가
120
가 가 가
(8) 100V 가

가 가
가 가